

Autonics

LONG DISTANCE INDUCTIVE PROXIMITY SENSOR (SPATTER RESISTANT TYPE)

PRDAT/PRDAWT SERIES

INSTRUCTION MANUAL



Thank you very much for selecting Autonics products.
For your safety, please read the following before using.

■ Safety Considerations

※ Please observe all safety considerations for safe and proper product operation to avoid hazards.
※ ⚠ symbol represents caution due to special circumstances in which hazards may occur.

⚠ Warning Failure to follow these instructions may result in serious injury or death.

⚠ Caution Failure to follow these instructions may result in personal injury or product damage.

⚠ Warning

1. **Fail-safe device must be installed when using the unit with machinery that may cause serious injury or substantial economic loss.** (e.g. nuclear power control, medical equipment, ships, vehicles, railways, aircraft, combustion apparatus, safety equipment, crime/disaster prevention devices, etc.)
Failure to follow this instruction may result in fire, personal injury, or economic loss.

2. **Do not disassemble or modify the unit.**
Failure to follow this instruction may result in fire.

3. **Do not connect, repair, or inspect the unit while connected to a power source.**
Failure to follow this instruction may result in fire.

4. **Check 'Connections' before wiring.**
Failure to follow this instruction may result in fire.

⚠ Caution

1. **Use the unit within the rated specifications.**
Failure to follow this instruction may result in fire or product damage.

2. **Use dry cloth to clean the unit, and do not use water or organic solvent.**
Failure to follow this instruction may result in fire.

3. **Do not use the unit in the place where flammable/explosive/corrosive gas, humidity, direct sunlight, radiant heat, vibration, impact, or salinity may be present.**
Failure to follow this instruction may result in fire or explosion.

4. **Do not supply power without load.**
Failure to follow this instruction may result in fire or product damage.

■ Ordering Information

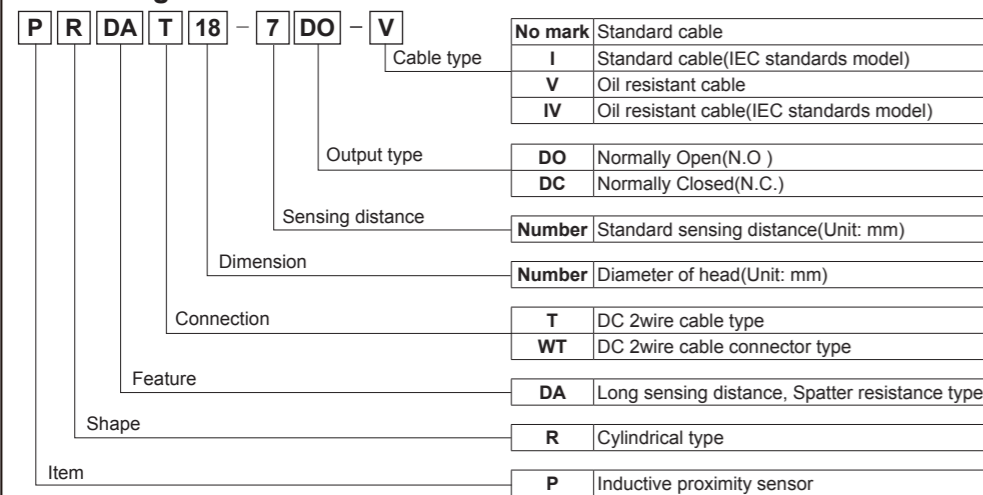

■ Control Output Diagram & Load Operating

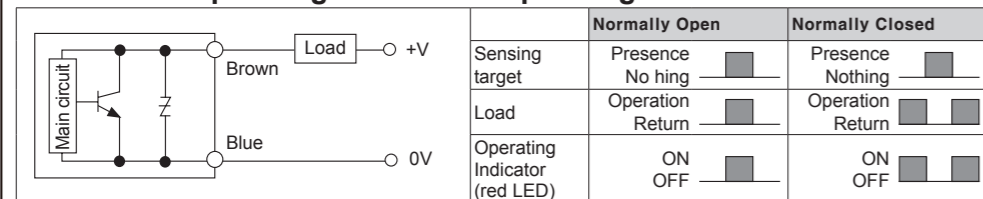

※ The above specifications are subject to change and some models may be discontinued without notice.
※ Be sure to follow cautions written in the instruction manual and the technical descriptions (catalog, homepage).

■ Specifications

Model	Cable type	PRDAT12-4DO PRDAT12-4DC PRDAT12-4DO-V PRDAT12-4DC-V	PRDAT18-7DO PRDAT18-7DC PRDAT18-7DO-V PRDAT18-7DC-V	PRDAT30-15DO PRDAT30-15DC PRDAT30-15DO-V PRDAT30-15DC-V
	Cable connector type	PRDAWT12-4DO PRDAWT12-4DC PRDAWT12-4DO-I PRDAWT12-4DC-I	PRDAWT18-7DO PRDAWT18-7DC PRDAWT18-7DO-I PRDAWT18-7DC-I PRDAWT18-7DO-IV PRDAWT18-7DC-IV	PRDAWT30-15DO PRDAWT30-15DC PRDAWT30-15DO-I PRDAWT30-15DC-I PRDAWT30-15DO-IV PRDAWT30-15DC-IV
Sensing distance		4mm	7mm	15mm
Hysteresis		Max. 10% of sensing distance		
Standard sensing target		12×12×1mm (Iron)	20×20×1mm (Iron)	45×45×1mm (Iron)
Setting distance		0 to 2.8mm	0 to 4.9mm	0 to 10.5mm
Power supply (Operating voltage)		12-24VDC (10-30VDC)		
Leakage current		Max. 0.6mA		
Response frequency		450Hz	250Hz	100Hz
Residual voltage		Max. 3.5V		
Affection by Temp.		Max. ±10% for sensing distance at ambient temperature 20°C		
Control output		2 to 100mA		
Insulation resistance		Min. 50MΩ (500VDC megger)		
Dielectric strength		1,500VAC 50/60Hz for 1 minute		
Vibration		1mm amplitude at frequency of 10 to 55Hz in each of X, Y, Z directions for 2 hours		
Shock		500m/s ² (approx. 50G) X, Y, Z directions for 3 times		
Indicator		Operating indicator (red LED)		
Environment	Ambient temperature	-25 to 70°C, Storage: -30 to 80°C		
	Ambient humidity	35 to 95%RH, Storage: 35 to 95%RH		
Protection circuit		Surge protection circuit, Overcurrent protection		
Protection		IP67 (IEC Standards)		
Cable	Cable type	Ø4mm, 2-wire, 2m	Ø5mm, 2-wire, 2m	Ø5mm, 2-wire, 2m
	Cable connector type	AWG22, Core diameter: 0.08mm, Number of cores: 60, Insulator out diameter: Ø1.25mm	Ø4mm, 2-wire, 300mm, M12 connector	Ø5mm, 2-wire, 300mm, M12 connector
Materials	Case/Nut	Teflon coated Brass, Washer: Teflon coated Iron, Sensing surface: Teflon		
	Standard cable	Black: Polyvinyl chloride (PVC), Oil resistant cable (Gray): Oil resistant Polyvinyl chloride (PVC)		
Approval		CE		
Weight	Cable type	Approx. 84g (Approx. 72g)	Approx. 134g (Approx. 122g)	Approx. 221g (Approx. 184g)
	Cable connector type	Approx. 54g (Approx. 42g)	Approx. 77g (Approx. 65g)	Approx. 155g (Approx. 143g)

※1: The response frequency is the average value. The standard sensing target is used and the width is set as 2 times of the standard sensing target, 1/2 of the sensing distance for the distance.
※2: Do not pull the Ø4mm cable with a tensile strength of 30N or over and the Ø5mm cable with a tensile strength of 50N or over. It may result in fire due to the broken wire.
When extending wire, use AWG22 cable or over within 200m.
※3: The weight with packaging and the weight in parentheses is only unit weight.
※ Environment resistance is rated at no freezing or condensation.

■ Dimensions

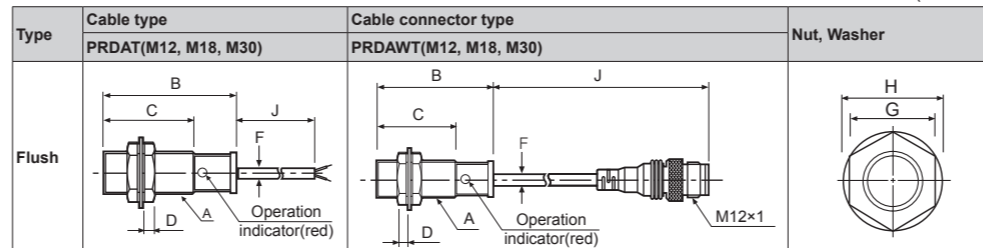

Type		A	B	C	D	F	G	H	J	
Flush	M12	PRDAT	M12×1	43	32	4	4	17	21	2,000
		PRDAWT	M12×1	43	32	4	4	17	21	300
	M18	PRDAT	M18×1	47.5	29.5	4	5	24	29	2,000
		PRDAWT	M18×1	47.5	29.5	4	5	24	29	300
	M30	PRDAT	M30×1.5	58.5	38.5	5	5	35	42	2,000
		PRDAWT	M30×1.5	58.5	38.5	5	5	35	42	300

■ Connections

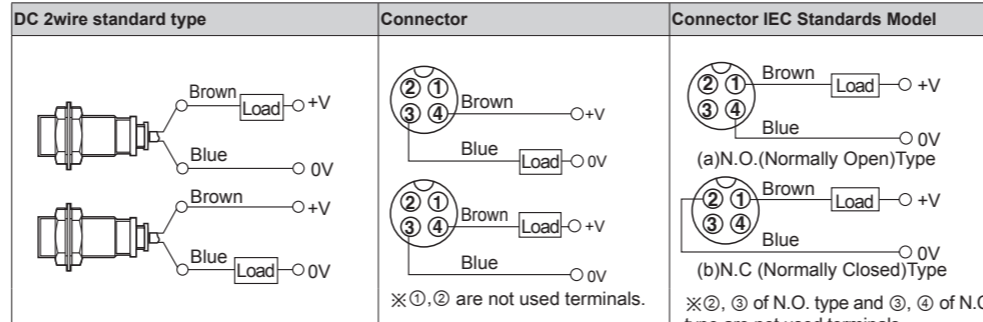

■ Mutual-interference & Influence by Surrounding Metals

● **Mutual-interference**
When several proximity sensors are mounted closely, malfunction of sensor may be caused due to mutual interference. Therefore, be sure to provide a minimum distance between the two sensors with referring to the chart below.

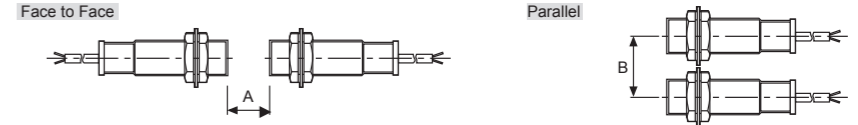

● **Influence by surrounding metals**
When sensors are mounted on metallic panel, it is required to protect the sensors from being affected by any metallic object except target. Therefore, be sure to provide a minimum distance as below chart.

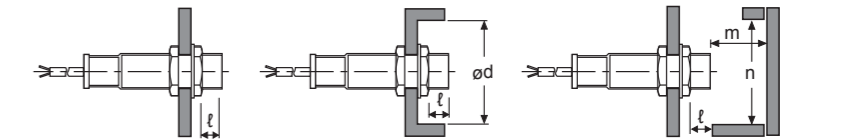

PRDAT12-4D				PRDAT18-7D				PRDAT30-15D			
A	24	ød	12	A	42	ød	18	A	90	ød	30
B	24	m	12	B	36	m	21	B	60	m	45
t	0	n	18	t	0	n	27	t	0	n	45

■ Setting Distance

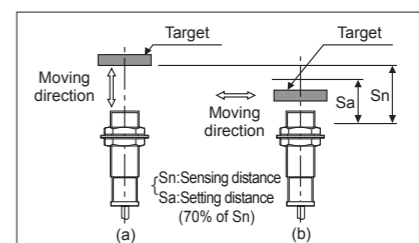

● Sensing distance can be changed by the shape, size or material of the target. Therefore please check the sensing distance like (a), then pass the target within range of setting distance (Sa).

● Setting distance (Sa) = Sensing distance (Sn) × 70%
E.g.) PRDAT18-7DO
Setting distance (Sa) = 7mm × 0.7 = 4.9mm

■ Installation and Tightening Torque

When tightening the nut, use the provided washer as [Figure 1]. When installing the product, the tightening torque of the nut varies according to the distance from the fore-end.

The front part of the product is from the fore-end to the dimension on the below table, and the rear part is from the tip of the nut to the end of the product. [Figure 2]

In case the nut is placed in the front part of the product, apply tightening torque for front part.

[Table 1] The allowable tightening torque table is for inserting the washer as [Figure 3].

[Table 1]

Model	Strength	Front		Rear
		Size	Torque	Torque
PRDAT12 PRDAWT12 Series	Flush	13mm	6.3N·m	11.76N·m
PRDAT18 PRDAWT18 Series		—	—	14.7N·m
PRDAT30 PRDAWT30 Series	—	26mm	49N·m	78.4N·m

[Figure 1]

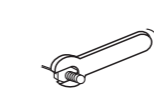

[Figure 2]

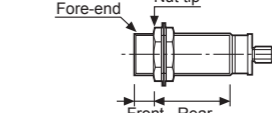

[Figure 3]

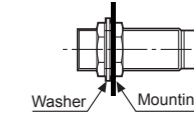

■ Caution during Use

- Follow instructions in 'Cautions during Use'. Otherwise, it may cause unexpected accidents.
- 12-24VDC power supply should be insulated and limited voltage/current or Class 2, SELV power supply device.
- Use the product, after 0.8 sec of supplying power.
- Wire as short as possible and keep away from high voltage lines or power lines, to prevent surge and inductive noise. Do not use near the equipment which generates strong magnetic force or high frequency noise (transceiver, etc.). In case installing the product near the equipment which generates strong surge (motor, welding machine, etc.), use diode or varistor to remove surge.
- If the surface of the product is rubbed with a hard object, PTFE coating can be worn out.
- This unit may be used in the following environments.
 - Ⓐ Indoors (in the environment condition rated in 'Specifications')
 - Ⓑ Altitude max. 2,000m
 - Ⓒ Pollution degree 2
 - Ⓓ Installation category II

■ Major Products

- Photoelectric Sensors
- Fiber Optic Sensors
- Door Sensors
- Door Side Sensors
- Area Sensors
- Proximity Sensors
- Pressure Sensors
- Rotary Encoders
- Connector/Sockets
- Switching Mode Power Supplies
- Control Switches/Lamps/Buzzers
- I/O Terminal Blocks & Cables
- Stepper Motors/Drivers/Motion Controllers
- Graphic/Logic Panels
- Field Network Devices
- Laser Marking System (Fiber, Co., Nd:Yag)
- Laser Welding/Cutting System
- Temperature Controllers
- Temperature/Humidity Transducers
- SSRs/Power Controllers
- Counters
- Timers
- Panel Meters
- Tachometers/Pulse (Rate) Meters
- Display Units
- Sensor Controllers